

## Description

Based on the most advanced digital integration technology, UTI6 intelligent temperature transmitter is a new generation intelligent meter for matching the demand of industrial automation control. UTI5 is made with rigorous structure and robust look. Its hardware uses few primary devices and does not have movable components like potentiometer....This product is featured with simple operation, good reliability and high stability.

UTI5 realizes communication through HART Protocol; it uses Frequency Shift Keying (FSK) technology according to industrial standard Bell202. Through using a high frequency signal on the 4-20mA output signal it realizes long-distance communication. The configuration data is stored in the non-volatility EEPROM memory of transmitter's PCB. This data could still be saved even when the power is therefore the transmitter can work immediately once it is powered.

UTI5 is widely used in chemical industry, petroleum industry, metallurgy industry, light industry, food industry, electric power plants, energy management etc.



## Features

- Suitable for different temperature transmitters
- Compact size, integrated configuration, real-time display
- Simple operation, do not use HART communicator, zero and span adjustment, range-setting, and gradual input can be realized through the keys on panel
- Has self-diagnosis function, long-distance configuration
- Precision / unit switching

## Specifications

measuring	gas or liquids compatible with stainless steel
temperature ranges	thermocouple: E: 0~750°C; K: 0~1200°C; S: 0~1300°C; B: 0~1600°C thermoresistor: PT100: -200~500°C
insert depth	50mm~2500mm (as customer's request)
accuracy	0.25%FS, 0.5%FS
output signal	4~20mA with HART protocol
long-term stability	<0.15%FS/year
supply voltage	24V±2V DC
insulation resistance	100MΩ@50VDC
operating temperature range	-20~+60°C
display	LCD digital indicator in °C unit
temperature coefficient of zero	0.2%FS/10°C
temperature coefficient of span	0.2%FS/10°C
process connection	M27×2 (male) or others
electrical connection	1/2NPT or M20×1.5 (female)
material of wet part	stainless steel
material of housing	cast aluminium
explosive-proof	Exia II BT4, Exd II BT4

# UTI5 Intelligent Temperature Transmitter

## Electrical connection

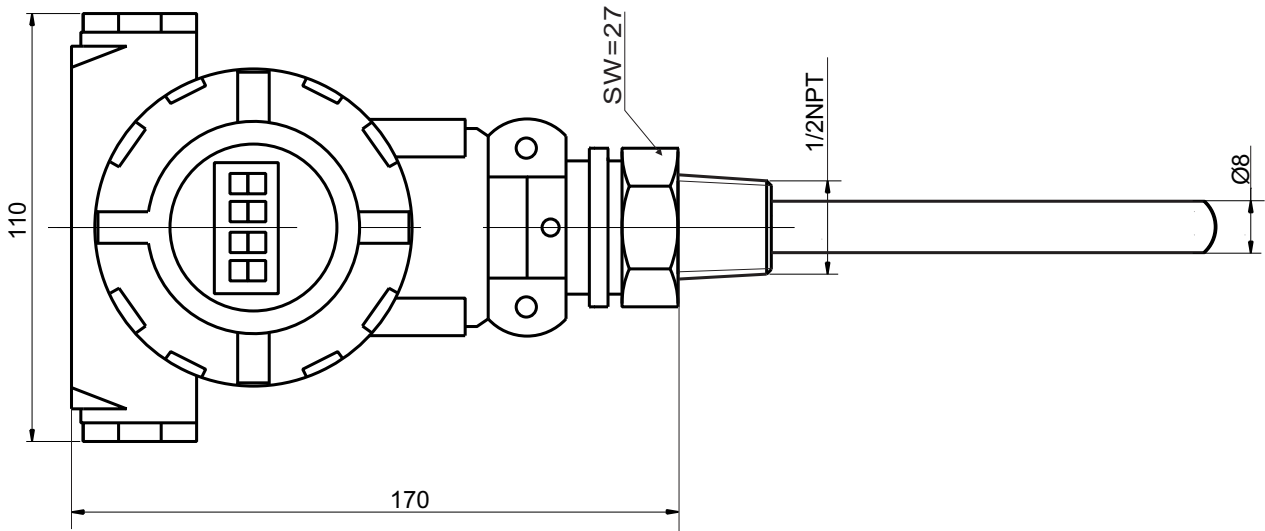

## Ordering code

UTI5		code	measuring range	code	accuracy	code	process connection
		E	0~750°C	C	0.25%FS	0	M20×1.5
		K	0~1200°C	D	0.5%FS	1	M27×2
		S	0~1300°C			2	undivided type
		B	0~1600°C			3	flange type
		Pt100	-200~500°C			Z	customer request
							insert depth L (mm)
UTI5	Pt100	0~200°C	D	P2	80		